

**VIRGINIA  
ABRASIVES®**

**REAL. RUGGED. READY.**

# **FG10 Floor Grinder**

## **Operating Manual**



**Model # FG-10**  
**Item # 433-50000**

Please read these instructions carefully before using.

CE  RoHS

	Page Number
Contents	2
Introduction and Description	3
Technical Data	4
Operation	4
Safety Precautions	6
Troubleshooting	7
Maintenance	8
Parts Diagram	9
Parts List	9

## Introduction and Description

This manual is intended to provide operation and service information necessary for the safe and efficient use of the Virginia Abrasives Floor Grinder. Operating or servicing the unit other than in accordance with the instructions given may subject the machine to conditions beyond its capability. This may result in the machine failure or personal injury.

### **IMPORTANT:**

**Read the entire operating manual carefully before attempting to use the floor grinder. Special attention should be given to the section entitled “Safety Precautions”.**

The floor grinder is a sturdy, reliable and easy to use machine.

The floor grinder is fitted with a 1.5 hp single phase motor. This motor offers a direct drive to the grinding plate by way of a flexible coupling between the motor and the plate.

The shroud system is unique in design by automatically adjusting to suit segment height and floor angle. This shroud system when used in conjunction with an appropriate industrial vacuum unit helps eliminate dust during grinding. The shroud has 2 removable sections to allow the operator to maneuver the grinder close to the wall. Please note that fugitive dust will likely occur when using the grinder with the two shroud sections removed.

The floor grinder comes complete with a water connection for wet grinding, if required. The water connection incorporates a ball valve that allows the operator to regulate the water supply to obtain the best grinding results.

The floor grinder has a foldable handle which enables it to be easily transported in the trunk of most vehicles. The rear wheels can be extended outward for added stability during use. The operator can raise or lower the height of the handle to maximize comfort.

The lightweight design makes the machine easy to lift.

## **Technical Data**

Motor HP	1.5 hp
Motor KW Rating	1.1 kw
Motor RPM	1730 rpm
Unit Weight	106 lbs. /48kg
Plate Type	Standard 10 inch grinding head
Plate Bolt Types	M12x25 countersunk socket head
Main Construction	Powder Coated Steel

## **Operation**

The floor grinder is designed to be used either wet or dry. If the application requires dry grinding, a suitable **industrial dust collection system** is required.

Consult Safety Data Sheets for the materials being ground. Concrete dust and floor coatings contain materials that can be harmful. **SEE SAFETY PRECAUTIONS FOR Silica Dust Warning.**

Contact your industrial hygiene professional for detailed information on required personal protective equipment PPE. Always use appropriate personal protective equipment (Hearing, Eye, Respiratory and Hand Protection).

## **Operating the Grinder**

1. Make sure the diamond tooling is suitable for the material being ground and that the tooling is correctly balanced.
2. Ensure that the grinding plates are in good condition and properly mounted. Never use damaged tooling.
3. All countersunk bolts must be tightened to specifications and firmly in place. Take periodic breaks to ensure that bolts are properly tightened, as they can loosen during operation.

4. Check that the grinding plate is adjusted so that it sits level on the work surface (use the bubble-level on the machine as a reference).
5. Check that all nuts and bolts on the folding handle latch are tight and secure.
6. Raise the grinding plates from the floor.
7. Start the motor by rotating the switch to the "ON" position.
8. Lower the grinding plate and begin grinding. Keep the grinding head moving side to side on the work surface to create an evenly ground surface until the desired results are reached.

### Stopping the Grinder

1. Rotate the power switch to the "OFF" position.

### Note:

The position of the axle may be adjusted as needed for leveling.

1. Adjust the vertical grinding position by loosening the level adjustment fastener counter clockwise.
2. Lifting the level adjustment handle raises the back end of the grinder.
3. Lowering the level adjustment handle lowers the back end of the grinder.
4. Use "bubble-level", mounted on the machine as a reference.
5. Secure desired grinder position by tightening the level adjustment fastener clockwise.

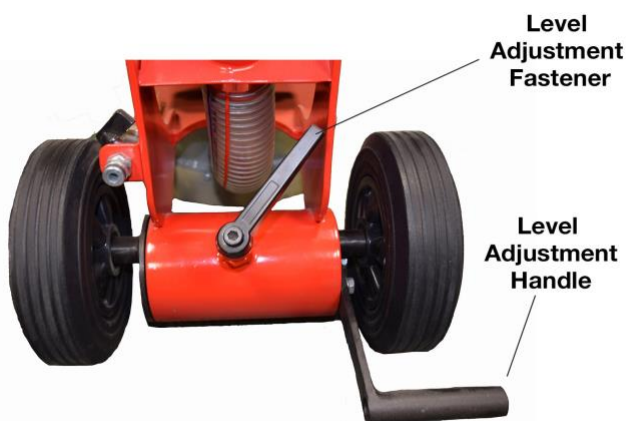

## **Safety Precautions**

The Virginia Abrasives Floor Grinder has been designed to minimize noise, vibration levels and to provide maximum operator safety. However, incorrect use of the grinder may cause serious injury and therefore the following precautions must be taken:

1. Do not use the grinder for longer than prescribed in your local environmental working regulations, as the noise load from extensive daily use may result in hearing damage.
2. Always use hearing protection, safety glasses, gloves and appropriate footwear.
3. Do not modify the grinder in any manner. Do not use a machine that has been modified by anyone other than the manufacturer or authorized dealers.
4. Do not add weight to the machine. Use different grinding plates to achieve the desired grinding performance.
5. Do not operate the grinder with the grinding head raised any higher than necessary. i.e. tipped back on handle.
6. Always be sure that folding handle latch is secure and has not become loose during use.
7. During normal use the machine is exposed to vibration. Occasionally check machine for bolts/nuts which may have vibrated loose.
8. Do not allow water or flammable materials to enter the interior of the motor.

## **Respirable Silica Dust Warning**

Grinding/cutting/drilling of masonry, concrete, metal and other materials can generate dust, mists and fumes containing chemicals known to cause serious or fatal injury or illness, such as respiratory disease, cancer, birth defects or other reproductive harm. If you are unfamiliar with the risks associated with the particular process and/or material being cut or the composition of the tool being used, review the Safety Data Sheets (SDS) and/or consult your employer, the manufacturers/suppliers, governmental agencies such as OSHA and NIOSH and

other sources on hazardous materials. The state of California and other authorities have published lists of substances known to cause cancer, reproductive toxicity, or other harmful effects.

Use engineering controls to control dust, mist and fumes at the source wherever possible. Use good work practices and follow the recommendations of the manufacturers/suppliers, OSHA/NIOSH, and occupational and trade associations. Water should be used for dust suppression when wet grinding/cutting/drilling is feasible. When the hazards from inhalation of dust, mists and fumes cannot be eliminated, the operator and any bystanders should always wear a respirator approved by NIOSH/MSHA for the material being used.

Grinding/cutting/drilling of masonry, concrete and other materials containing silica may generate dust or mists containing crystalline silica. Silica is a basic component of sand, quartz, brick clay, granite and numerous other minerals and rocks. Repeated and/or substantial inhalation of airborne crystalline silica can cause serious or fatal respiratory diseases, including silicosis. The state of California and other authorities have listed respirable crystalline silica as a substance known to cause cancer. When grinding/cutting/drilling such materials, always follow the respiratory precautions mentioned above.

### **Troubleshooting**

<b>Symptom</b>	<b>Possible Cause</b>	<b>Action</b>
Grinder runs for short time then stops	The electrical power current limit or thermal overload has been exceeded.	Allow the motor and thermal overload to cool and automatically reset.
Grinder runs but does not perform adequately.	Tooling is not matched to the application	Re-evaluate and modify tooling selection as needed.
Grinder vibrates during use	Grinder tooling is not correctly balanced	Replace grinder tooling
Grinding noise coming from grinding head under no-load operation.	Worn motor bearings or drive coupling	Have machine evaluated and serviced by authorized service professional.

## **Maintenance**

Daily cleaning: The motor should always be kept clean. No water, or foreign materials should be allowed to get into the interior of the motor.

Check operating amperage draw: While the motor is in operation, take care to keep the operating amperage below maximum level.

Operational sounds: During operation of the motor there must be no rubbing sounds, squeals or other random noises. Stop the motor immediately and restart after inspection and corrections have been made.

Check the security of the adjustable folding handle latch periodically.

The wheel bearings use sealed bearings and require no regular greasing.



# Parts Diagram

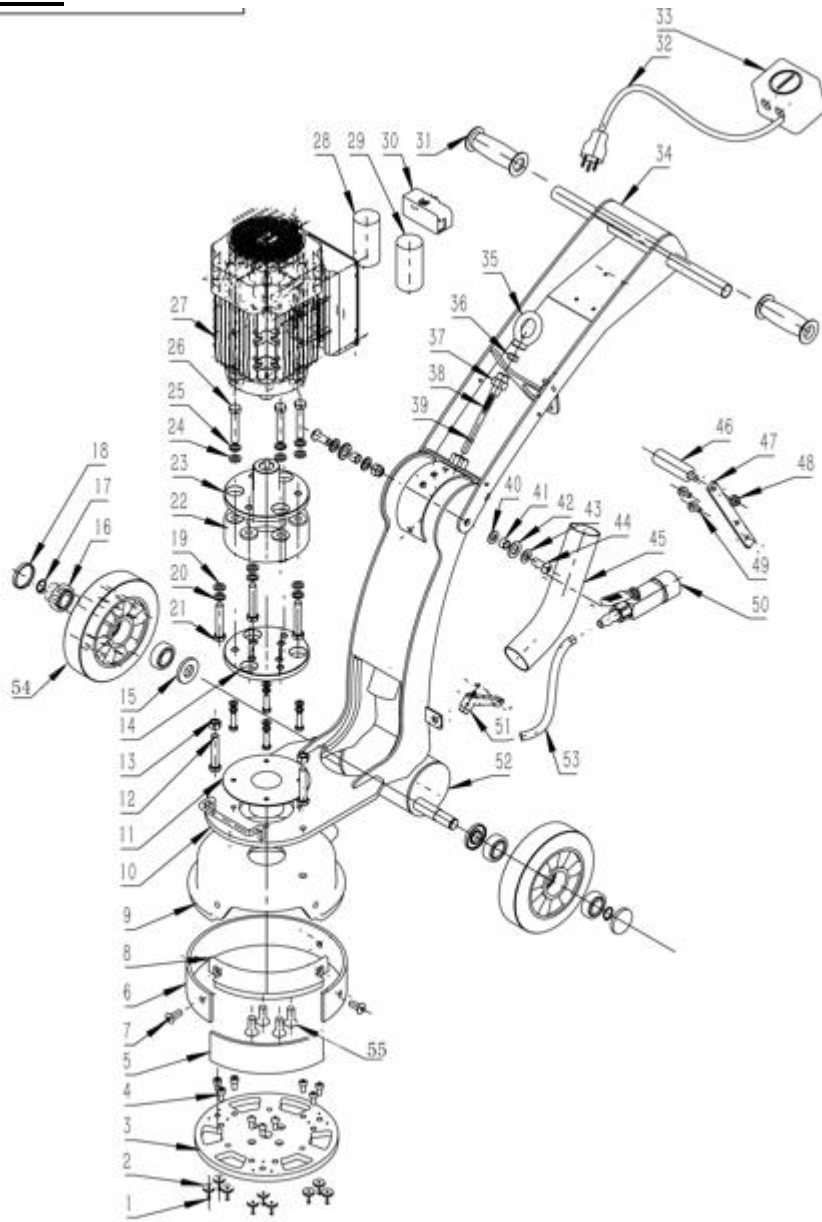

Diagram#	Item#	Item Description	QTY
1	434-50001	Magnet	1 Ea
2	434-50002	Bolt M4*10	1 Ea
3	434-50003	Plate	1 Ea
4	434-50004	Bolt M8*16	1 Ea
5	434-50005	Dust Shroud 1	1 Ea
6	434-50006	Dust Shroud 2	1 Ea
7	434-50007	Bolt M10	1 Ea
8	434-50008	Metal cover-1	1 Ea
9	434-50009	Metal cover-2	1 Ea
10	434-50010	Frame Body part 1	1 Ea
11	434-50011	Flange-1	1 Ea
12	434-50012	Bolt M12*65	1 Ea
13	434-50013	Nut M12	1 Ea
14	434-50014	Plate connector	1 Ea
15	434-50015	Washer	1 Ea
16	434-50016	Bearing 6204	1 Ea
17	434-50017	CirclipsΦ20	1 Ea
18	434-50018	Plastic Bearing cover	1 Ea
19	434-50019	Nut M12	1 Ea
20	434-50020	Washer	1 Ea
21	434-50021	Bolt M12*65	1 Ea
22	434-50022	Rubber Disc	1 Ea
23	434-50023	Flange-2	1 Ea
24	434-50024	Nut M12	1 Ea
25	434-50025	Washer	1 Ea
26	434-50026	Bolt M12*65	1 Ea
27	434-50027	Electrical motor	1 Ea

28	434-50028	Run capacitor	1 Ea
29	434-50029	Start capacitor	1 Ea
30	434-50030	Electronic Overload switch	1 Ea
31	434-50031	Handle sleeve	1 Ea
32	434-50032	Power Connection (pigtail)	1 Ea
33	434-50033	Switch	1 Ea
34	434-50034	Frame Body part 2	1 Ea
35	434-50035	Ring-pull	1 Ea
36	434-50036	Nut M10	1 Ea
37	434-50037	Connector	1 Ea
38	434-50038	Spring	1 Ea
39	434-50039	Joint pin	1 Ea
40	434-50040	Washer	1 Ea
41	434-50041	Copper rings	1 Ea
42	434-50042	Washer	1 Ea
43	434-50043	Washer	1 Ea
44	434-50044	Bolt M12*30	1 Ea
45	434-50045	Dust collection pipe	1 Ea
46	434-50046	Eccentric Adjustment Handle	1 Ea
47	434-50047	Connecting rod	1 Ea
48	434-50048	Nut M12	1 Ea
49	434-50049	Bolt M8*16	1 Ea
50	434-50050	Control valve	1 Ea
51	434-50051	Height Adjustment Handle M12*25	1 Ea
52	434-50052	Eccentric shaft	1 Ea
53	434-50053	Water Hose	1 Ea
54	434-50054	Wheel	1 Ea
55	434-50055	Bolt M12*25	1 Ea