

# **VIRGINIA ABRASIVES<sup>®</sup>**

**REAL. RUGGED. READY.**

## **Operator's Manual FS-18M Floor Saw**



# Table of Contents

- 1. SAFETY INFORMATION.....2**
- 1.1 Operating Safety.....2
- 1.2 Operator Safety while using Internal Combustion Engines.....3
- 1.3 Diamond Blade Safety.....3-4
- 1.4 Transportation Safety.....4
- 1.5 Maintenance Safety .....4
- 1.6 Label Locations.....5
- 1.7 Safety and Operating Labels.....6-7
  
- 2. OPERATION ..... 8**
- 2.1 Operation Principle .....8
- 2.2 Delivery Checks .....8
- 2.3 Application-Standard Features .....8
- 2.4 Cutting depth setting .....9
- 2.5 Depth of cut indicator .....9
- 2.6 Water tank .....9
- 2.7 Assembling the cutting blade .....
- 2.8 Before Starting .....9
- 2.9 To Start .....9
- 2.10 To Stop .....9
  
- 3. MAINTENANCE ..... 10**
- 3.1 Periodic Maintenance Schedule.....10
- 3.2 Transporting Cutters.....11
- 3.3 Belt Inspection .....11
- 3.3 Trouble Shooting .....12
  
- 4. TECHNICAL DATA ..... 13**

# 1. SAFETY INFORMATION

## 1.1 Operating Safety

- Only trained personnel are permitted to start, operate, and shut down the machine. Trained personnel have received instruction on how to properly use the machine and are familiar with required safety devices
- The machine must not be accessed or operated by those impaired by alcohol or drugs.
- NEVER operate this machine in an application for which it is not intended.
- NEVER allow anyone to operate this equipment without proper training. Individuals operating this equipment must be familiar with the risks and hazards associated with it.
- NEVER operate the machine with the belt guard missing. Exposed drive belts and pulleys create hazards that can cause serious injuries.
- DO NOT allow anyone to stand or lean on the unit during operation.
- Do not run the machine indoors or in an enclosed area such as a deep trench unless adequate ventilation is provided. Engine exhaust contains carbon monoxide which is a poison you cannot see or smell. Exposure to carbon monoxide can cause loss of consciousness, bodily harm and death.
- Do not operate the machine with unapproved accessories or attachments.
- ALWAYS wear protective clothing and appropriate personal protective equipment when operating the machine.
- ALWAYS close fuel valve on engines equipped with one when machine is not being operated.
- ALWAYS store the machine properly when it is not being used. The machine should be stored in a clean, dry location.
- Before starting operation, check that all controls and safety devices are functioning properly.
- Never operate the machine in a potentially explosive environment.
- Never leave the machine running unattended!
- Incorrect operation or misuse by untrained personnel can endanger the health and safety of the operator and others. Incorrect operation can also cause damage to the machine.
- Read, understand and follow procedures in the Operator's Manual before attempting to operate the machine.

## 1.2 Operator Safety while using Internal Combustion Engines

- DO NOT smoke when refueling the engine.
- DO NOT refuel a hot or running engine.
- DO NOT refuel the engine near an open flame or other combustion sources.
- Do not touch the engine or muffler while the engine is on or immediately after it has been turned off. These areas get hot and may cause serious burns.
- If fuel is spilled during refueling, wipe it off from the engine immediately and discard the rag in a safe place. Do not operate the unit if fuel or oil leaks from machine.
- NEVER operate equipment in a poorly ventilated or enclosed area.

- NEVER perform any work on the unit while it is running.
- Avoid prolonged breathing of exhaust gases.
- Avoid contact with hot exhaust systems and engine parts.
- Allow engine to cool before performing any repairs or service.
- ALWAYS transport and handle fuel when contained in approved safety containers.
- ALWAYS keep the area around the muffler free of debris such as leaves, paper, cartons, etc. A hot muffler could ignite debris.

### **1.3 Diamond Blade Safety**

- Use appropriate diamond blades manufactured for the use on floor saws.
- Always inspect diamond blades before each use. The blade should exhibit no cracks, dings, or flaws in the steel core or rim. Center (arbor) hole must be undamaged and true.
- Examine blade flanges for damage, excessive wear and cleanliness before mounting blade. Blade should fit snugly on the shaft and against the inside/outside blade flanges.
- Ensure that the blade is marked with an operating speed greater than the blade shaft speed of the cutter. Never exceed the maximum RPM speed marked on the blade.
- Only cut the material that is specified by the diamond blade. Read the specifications of the diamond blade to ensure the proper tool has been matched to the material being cut.
- Always keep blade guards in place. Exposure of the diamond blade must not exceed 180 degrees.
- Ensure that the diamond blade does not come into contact with ground or surface during transportation. Do not drop the diamond blade on ground or surface.
- The engine governor is designed to permit maximum engine speed in a no-load condition. Speeds that exceed this limit may cause the diamond blade to exceed the maximum safe allowable speed. DO NOT modify the engine speed or the belt pulley diameter.
- Ensure that the blade is mounted for proper operating direction.

### **1.4 Transportation Safety**





- Use the lifting bail and appropriate lifting equipment to ensure the safe movement of the cutter.
- Do not use the handle bars and/or front pointer as lifting points.
- Never tow the saw behind a vehicle.
- Ensure that both pointer bars are positioned appropriately to minimize the possibility of damage during transportation.
- Safeguard against extreme cutter attitudes relative to level. Engines tipped to extreme angles may cause oil to gravitate into the cylinder head making the engine difficult to start.
- Never transport the cutter with the blade mounted.



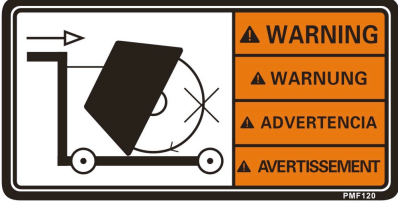

### **1.5 Maintenance Safety**

- Never lubricate components or attempt service on a running machine.
- Always allow the machine a proper amount of time to cool before servicing.

- Perform regularly scheduled maintenance to keep the machinery in peak operating condition.
- Fix damage to the machine immediately and always replace broken parts.
- Dispose of hazardous waste properly. Examples of potentially hazardous waste are used motor oil, fuel and fuel filters.
- Do not use food or plastic containers to dispose of hazardous waste.

### 1.6 Safety and Operating Labels

Label	Meaning
	<p><b>DANGER!</b> Engines emit carbon monoxide; operate only in well-ventilated area. Read the Operation Manual for machine information. No sparks, flames, or burning objects near the machine. Shut off the engine before refueling. Use only clean, filtered unleaded gasoline.</p>
	<p><b>WARNING!</b> Cutting hazard. Always replace blade guard!</p>
	<p><b>WARNING!</b> Machine may not be offset with the cutting blade rotating.</p>
	<p><b>CAUTION!</b> Read and understand the supplied Operator's Manual before operating the machine. Failure to do so increases the risk of injury to yourself or others.</p>
	<p><b>WARNING!</b> Always wear hearing and eye protection when operating this machine.</p>

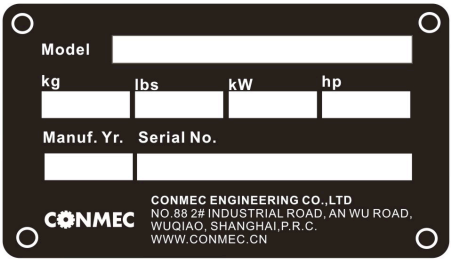
Label	Meaning
	<p><b>WARNING!</b> Hand injury if caught in moving belt. Always replace belt guard.</p>
	<p><b>CAUTION!</b> Lifting point.</p>
	<p><b>CAUTION!</b> Use only clean, filtered fuel.</p>
	<p><b>WARNING!</b> Hot surface!</p>
	<p>A nameplate listing the model number and serial number is attached to each unit. Please record the information found on this plate so it will be available if the nameplate is lost or damaged. When requesting service information, the serial number should be specified of the unit.</p>

## 1.8 Silica Dust Warning

**WARNING:** Cutting, grinding, sawing, drilling, sanding, or polishing construction materials and surfaces generates dust and particulates which may be harmful if inhaled. Proper respiratory protection and adequate ventilation should be maintained at all times while engaging in these activities.

## 2. OPERATION

### 2.1 Operating Principle

The following instructions were compiled to provide you information on how to obtain long and trouble free use of the machine. Periodic maintenance of the machine is essential. Read the manual carefully and thoroughly familiarize yourself with the machine and all it's functions. Failure to do so may injure yourself or a bystander.

### 2.2 Delivery Checks

Immediately on taking delivery of your new machine and before putting it into service.

- Read the operator's manual thoroughly—doing so could prevent unnecessary loss of time and expense. Read the engine manual supplied.
- Check the general condition of the machine – has it been damaged during delivery?
- Check engine oil level.
- Check fuel level.

Recommended lubricants are detailed in the Care and Maintenance section.

### 2.3 Application-Standard Features

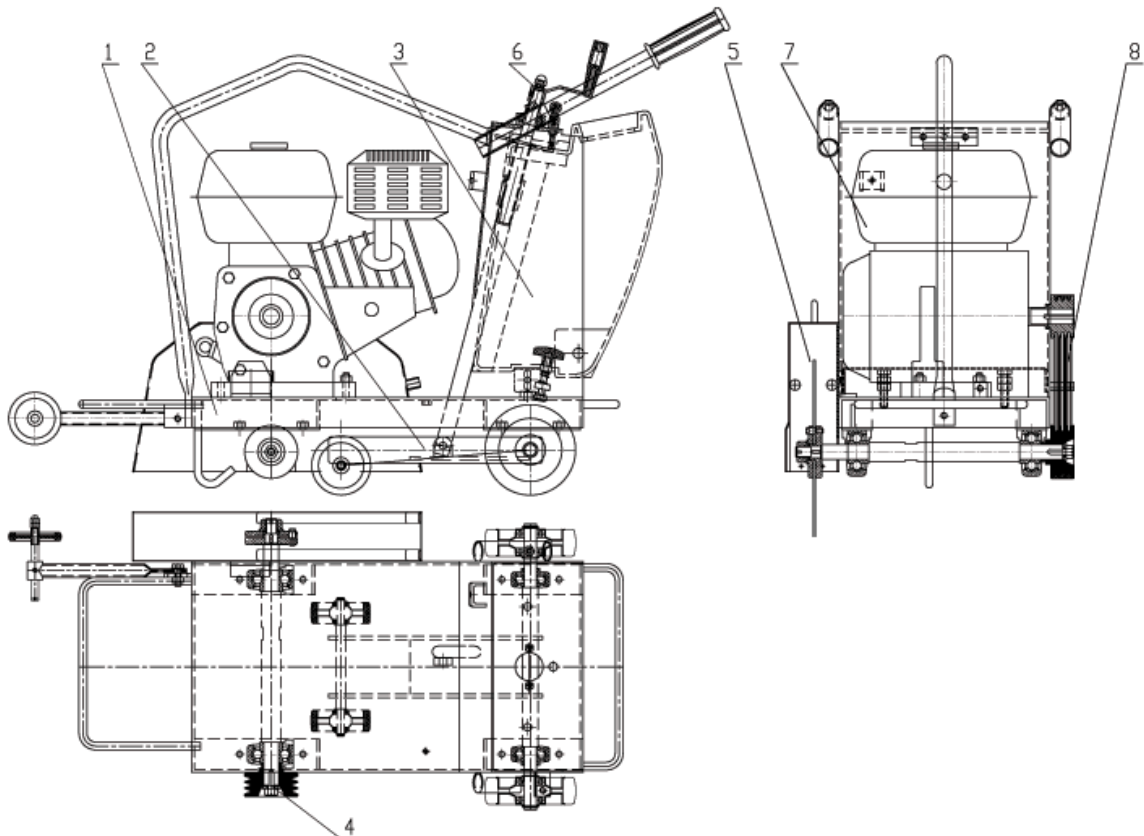

Ref. No.	Description	Ref. No.	Description
1	Frame	5	Blade Guard
2	Wheel Shaft	6	Cutting Depth Adjustment Crank
3	Water Tank Assy.	7	Engine
4	Shaft Assy.	8	Belt

## 2.4 Cutting depth setting

With the crank you can set the cutting depth precisely. Turn the crank in the clockwise direction to increase the cutting depth and turn it in the counterclockwise direction to reduce the cutting depth.

## 2.5 Depth of cut indicator

Use the indicator to check the cutting depth currently set. It features a cm-scale. Adjust it to the diameter of the blade currently installed to obtain the correct value. To do this, turn the crank until the blade touches the ground, loosen the clamp and push the sleeve with the scale up to the bottom of the sleeve. Then tighten the clamp again.

## 2.6 Water tank

The FS-18M features an integrated, removable water tank.

To fit the water tank, attach the retaining clamp and tighten it with the strap.

To remove the water tank or to attach an external water supply, you can disconnect the hose in two different spots.

The amount of water can be regulated or stopped.

## 2.7 Blade Installation

1. Checking a new cutting blade:

- The blade type must be suitable for the material to be cut. Observe the peripheral speed, refer to the "Technical data"!
- The arbor diameter of the cutting blade must precisely fit the shaft to ensure smooth blade running.
- The cutting blade must be undamaged.

**NOTICE:** Observe the correct direction of rotation of the cutting blade! That means the rotational direction mark on the cutting blade must correspond with the rotational direction mark on the cutting blade guard.

2. Open the blade guard.

3. Prior to the installation of the cutting blade, clean the spring washers and the locking pin and check them for damage.

4. Attach cutting blade and spring washer on the shaft.

5. Tighten the hexagonal head bolt firmly. To do this, apply counter pressure on the spanner surfaces of the cutting shaft.

6. Close and lock blade guard.



**NOTICE:** Starting the machine is only permitted with a water hose connected and the water supply turned on.

## **2.8 Before Starting**

Before starting the machine, check the following items:

- All handles are free from grease, oil and dirt.
- All control levers are in the neutral position.
- All bolted joints are tightened and guards are in place.
- Fuel level
- Oil level in the engine
- Air cleaner maintenance indicator

**NOTICE:** Check the oil level in the engine and machine before starting. The warranties are VOID if the machine runs without oil.

## **2.9 To Start**

1. Start engine and allow the engine to warm up for several minutes.
2. All cutting should be done at full throttle.
3. Align blade and cutter with cut. Open water valve and turn water safety switch on.
4. Lower blade into cut slowly.
5. Cut as fast as blade will allow. If the motor strains or the blade rises out of the cut, reduce forward speed or depth of cut.
6. Use only enough side pressure on cutter handles to follow cutting line.

## **2.10 To Stop**

1. Stop forward cutting motion to relieve pressure from the blade.
2. Move throttle lever to the idle (lowest speed) and move the ON/OFF switch to the "OFF" position.
3. Remove the blade from the cut.

### 3 MAINTENANCE

#### 3.1 Periodic Maintenance Schedule

The chart below lists basic trowel and engine maintenance. Refer to engine manufacturer's Operator's Manual for additional information on engine maintenance. A copy of the engine Operator's Manual was supplied with the machine when it was shipped. To service the engine, tilt the seat forward.

	Daily	Every 20 hours	Every 50 hours	Every 100 hours	Every 200 hours	Every 300 hours
Check fuel level.	●					
Check engine oil level.	●					
Inspect air filter. Replace as needed.	●					
Check external hardware.	●					
Replace the engine oil		●				
Clean air filter		●				
Check drive belt for wear.			●			
Change engine oil.				●		
Check fuel filter.				●		
Clean and check spark plug.					●	
Replace oil filter.					●	
Replace spark plug.						●
Replace fuel filter.						●
Check the cutting blade for damage and tightness	●					
Check the direction of rotation arrow of the cutting blade	●					
Check that the height adjustment moves freely	●					
Check the water supply	●					

### 3.2 Transporting the cutter

- Always shut off engine when transporting machine.
- Make sure lifting device has enough capacity to hold machine (see identification plate on machine for weight).
- Use lifting hook (a) when lifting machine.



### 3.3 Belt Inspection

Check the belt weekly during engine maintenance and retighten it as follows, if necessary:

1. Remove the belt guard.
2. Loosen the jam nut.
3. Loosen the four fastening nuts of the engine until the engine can be moved without play.
4. Tighten the belt with the tension screw.
5. If necessary, correct the parallel alignment of the engine. As a first step, tighten a fastening nut of the engine and correct the alignment by means of the tension screw.
6. Tighten all fastening nuts of the engine as well as the jam nut.
7. Install the belt guard.

### 3.4 Trouble Shooting

SYMPTOM	POSSIBLE CAUSES	SOLUTION
Engine running rough or not at all.	Fuel?	Look at the fuel system. Make sure there is fuel being supplied to the engine. Check to ensure that the fuel filter is not clogged.
	Ignition?	Check to ensure that the ignition switch has power and is functioning correctly.
Engine does not start	The main switch is in the "0" position.	Set the main switch to the "I" position.
	Fuel tap is closed.	Open the fuel tap.
	Fuel tank is empty.	Top up with fuel.
	Fuel line is clogged.	Have the fuel line cleaned.
	Fuel filter is clogged.	Have the fuel filter replaced.
	Carburetor is clogged.	Have the carburetor cleaned.
	Air cleaner is clogged.	Clean or replace air cleaner.
	Spark plug cap is defective.	Have the machine repaired.
	Spark plug is defective.	Change the spark plug.
	Spark plug is loose.	Tighten the spark plug.
	Spark plug gap is set incorrectly.	Set the spark plug gap.
Insufficient engine oil.	Top up with engine oil.	
Engine shuts off right after starting.	Idle speed is adjusted incorrectly.	Set idle speed.
	Fuel tank is empty.	Top up with fuel.
	Fuel filter is clogged.	Have the fuel filter replaced.
	Air cleaner is dirty.	Clean or replace air cleaner.
	Insufficient engine oil.	Top up with engine oil.
Engine has low performance.	Air cleaner is dirty.	Clean or replace air cleaner.
Recoil starter defective.	Starter rope jammed.	Have the starter rope replaced.
	Starter rope torn off.	
Cutting blade does not rotate.	The belt is faulty.	Replace the belt.
Engine cannot be turned off.	Electrical connection of the main switch is defective.	1. Close the fuel tap. The engine will switch off after a few seconds. 2. Have the machine repaired.

#### 4. TECHNICAL DATA

<b>Model:</b>	<b>FS18M</b>
<b>Engine Type:</b>	<b>Honda</b>
<b>Power:</b>	<b>9HP (6.6kw)</b>
<b>Weight:</b>	<b>191 lbs. (87 kg)</b>
<b>Max. Cutting Depth:</b>	<b>4.7 In. (12cm)</b>
<b>Blade Size:</b>	<b>14" In</b>
<b>Water Tank Capacity:</b>	<b>25 Liters</b>
<b>Depth Adjustment:</b>	<b>Handle Rotation</b>
<b>Driving:</b>	<b>Manual Push</b>

**Working Size (L x W x H):** 72 In. x 19 ½ In. x 31 In. (1840mm x 500mm x 780mm)

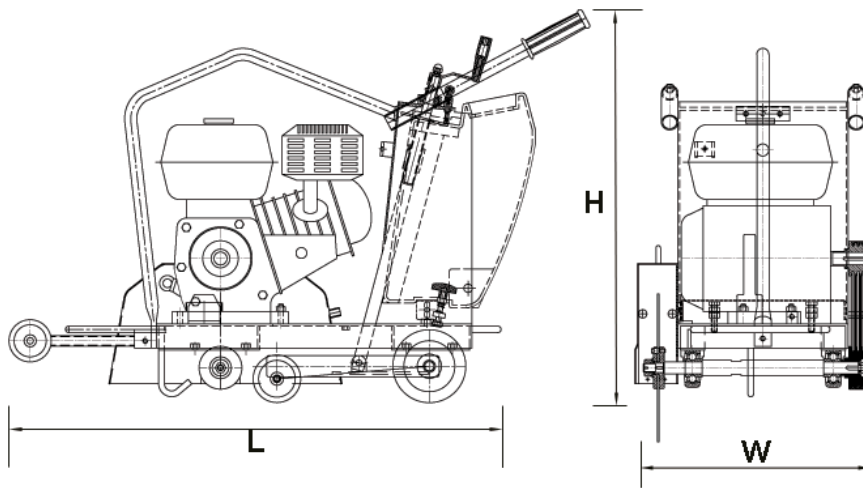

#### **Sound Specification (According to DIN EN 13862):**

The sound pressure level measured (LpA): 103 dB(A)

The guaranteed sound power level (LWA): 105 dB(A)

#### **Vibration Specification (According to DIN EN 13862):**

Uncertainty of measurement of vibration total value  $a_{hv}$ :  $1.6m/s^2$